

Owner's Manual

- *Installation*
- *Use*
- *Maintenance*



MF45 - MF50 - MF55



INDEX

1.	INTRODUCTION	Page 3
2.	DESCRIPTION OF SYMBOLS	Page 3
3.	SAFETY	Page 4
	3.1 General safety instructions	Page 4
	3.2 High pressure unit safety requirements	Page 4
	3.3 Safety during operation	Page 4
	3.4 General procedures for using nozzles	Page 4
	3.5 Safety during unit maintenance	Page 5
4.	PUMP IDENTIFICATION	Page 5
5.	TECHNICAL FEATURES	Page 6
6.	DIMENSIONS AND WEIGHT	Page 6
7.	OPERATING INSTRUCTIONS	Page 7
	7.1 Water temperature	Page 7
	7.2 Maximum flow and pressure rates	Page 7
	7.3 Minimum RPM	Page 7
	7.4 Recommended lubricant types and Manufacturers	Page 7-8
8.	PORTS AND CONNECTIONS	Page 9
9.	PUMP INSTALLATION	Page 9
	9.1 Installation	Page 9
	9.2 Direction of rotation	Page 10
	9.3 Version change and reducer positioning	Page 10-11
	9.4 Hydraulic connections	Page 12
	9.5 Pump power supply	Page 12
	9.6 Suction line	Page 12
	9.7 Filtration	Page 13
	9.8 Outlet line	Page 14
	9.9 Internal diameter of hose	Page 14
	9.10 V-belt transmission	Page 15
10.	START UP AND OPERATION	Page 15
	10.1 Preliminary inspections	Page 15
	10.2 Starting up	Page 16
11.	PREVENTATIVE MAINTENANCE	Page 16
12.	PUMP STORAGE	Page 17
	12.1 Filling the pump with anti-corrosion emulsion or anti-freeze	Page 17
	12.2 Hoses	Page 17
13.	PRECAUTIONS AGAINST FREEZING	Page 17
14.	WARRANTY TERMS	Page 17
15.	TROUBLESHOOTING	Page 18
16.	EXPLODED VIEWS AND PARTS	Page 19-20
17.	REPAIR TOOLS	Page 21
18.	MAINTENANCE LOG	Page 22

1. INTRODUCTION

This manual describes the use and maintenance instructions of the MF pump, and should be carefully read and understood before using the pump.

Correct use and adequate maintenance will guarantee the pumps trouble-free operation for a long time. General Pump declines any responsibility for damage caused by misuse or the non-observance of the instructions indicated in this manual.

Upon receiving the pump, check that it is complete and in perfect condition. Should anything be found out of order, please contact us before installing and starting the pump.

2. SYMBOL DESCRIPTIONS



Warning
Potential Danger

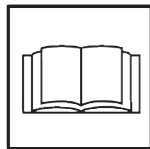

Read carefully and understand the manual before operating the pump



Danger
High Voltage



Danger
Wear protective mask



Danger
Wear goggles



Danger
Wear protective gloves



Danger
Wear protective boots



Symbol for protection against explosion.

This defines special safety requirements for the use of the pumps in areas identified in accordance with the ATEX Directive.

When pumps are ordered in the ATEX configuration because they are going to work in areas with a potentially explosive atmosphere, you must **STRICTLY comply with the notes given under the headings marked with this symbol and the instructions in the supplementary instructions manual "ATEX EXPLOSION PROTECTION"**.

(Versions available in compliance with ATEX:MF)

3. SAFETY

3.1 General Safety Indications

Improper use of pumps and high pressure systems, and the non-compliance with installation and maintenance instructions may cause severe injury to people and/or damage to property. Anyone assembling or using high pressure systems must possess the necessary competence to do so, should be aware of the characteristics of the components assembled/used, and must take all precautions necessary to ensure maximum safety in any operating condition. In the interest of safety, both for the Installer and the Operator, no reasonably applicable should be omitted.

3.2 High pressure unit safety requirements

1. The pressure line must always be equipped with a safety valve.
2. High pressure system components, in particular for those units working outside, must be adequately protected against rain, frost and heat.
3. The electrical control system must be adequately protected from water spray, and must comply with the specific regulations in force.
4. High pressure hoses must be properly sized for maximum operating pressure of the system and always and only used within the operating pressure range specified by the hose manufacturer. The same rules should be observed for all other auxiliary systems affected by high pressure.
5. The ends of high pressure hoses must be sheathed and secured to a solid structure to prevent dangerous whiplash in case of bursting or broken connections.
6. Appropriate safety guards must be provided for the pump transmission systems (couplings, pulleys and belts, auxiliary drives).



3.3 Safety During Operation

The working area of a high pressure system must be clearly marked. Access must be prohibited to un-authorized personnel and, wherever possible, the area should be restricted or fenced. The personnel authorized to access this area should first be trained, and informed about the risks that may arise from failures or malfunctions of the high pressure unit.

Before starting the unit, the operator must check:

1. That the high pressure system is properly powered (see paragraph 9.5).
2. That pump intake filters are perfectly clean; we advise the use of a device that indicates the filters clogging level.
3. Electrical parts are adequately protected and in perfect condition.
4. The high pressure hoses do not show apparent signs of abrasion, and that fittings are in perfect shape.

Any fault or reasonable doubt that may arise before or during operation should be promptly reported and verified by competent personnel. In these cases, pressure should immediately be released and the high pressure system stopped.



3.4 General Procedures For Using Nozzles

1. The Operator must always place his/her safety and security first, as well as that of others that may be directly affected by his/her actions, or any other assessments or interests. The operator's work must be dictated by common sense and responsibility.
2. The Operator must always wear a helmet with a protective visor, waterproof clothing, and appropriate boots capable of guaranteeing grip on wet pavement.

Note: appropriate clothing will effectively protect against water spray, but it may not offer adequate protection against the direct impact of water jets or sprays from a close distance. Some circumstances may require further protection.

3. It is generally best to organize personnel into teams of at least two people capable of giving mutual and immediate assistance in case of necessity and of taking turns during long and demanding operation.
4. Access to the work area that is within the water jets' range must be absolutely prohibited to and free from objects that, inadvertently under a pressure jet, can be damaged and or create dangerous situations.
5. The water jet must only and always be directed in the direction of the work area, including during testing or preliminary tests or checks..
6. The Operator must always pay attention to the trajectory of the debris removed by the water jet. If necessary, suitable guards must be provided by the Operator to protect anything that may be accidentally exposed.
7. The Operator should not be distracted for any reason during operation. Workers needing to access the operating area must wait for the Operator to stop work, and then immediately make their presence known.
8. For safety reasons, it is important that each member of the team is fully aware of the intentions and actions of other team members in order to avoid dangerous misunderstandings.
9. The high pressure system must not be started up and run under pressure without all team members in position and without the Operator having already directed his/her lance toward the work area.

3.5 Safety During System Maintenance

1. The pressure system maintenance must be carried out in the time intervals set by the manufacturer who is responsible for the whole group according to law.
2. Maintenance should always be carried out by trained and authorized personnel.
3. Assembly and disassembly of the pump and its various components must be performed exclusively by authorized personnel, using appropriate equipment in order to avoid damage to components and connections.
4. Always use original spare parts to ensure total reliability and safety.

4. PUMP IDENTIFICATION

Each pump has a specific label (1, fig. 1) which contains:

Pump model and version
 Serial Number
 Maximum RPM
 Power Hp-kW
 Pressure - P.S.I.
 Flow Rate - GPM

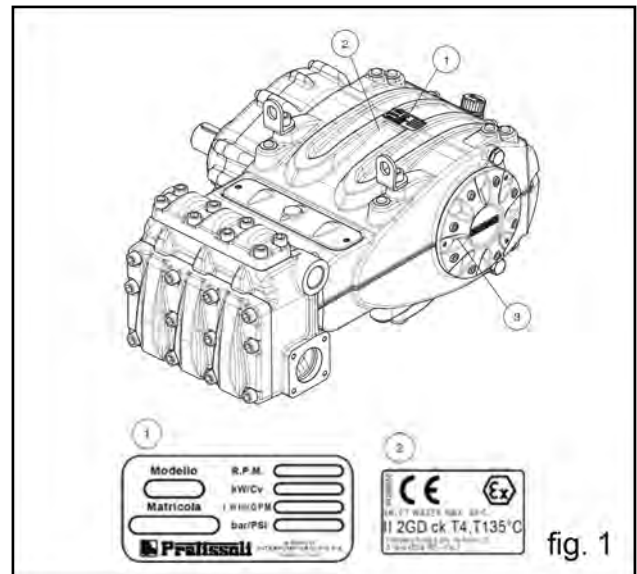

For pumps ordered with the ATEX configuration.
 (2, fig. 1) **With specific ATEX marking for explosion protection.**
 (3, fig. 1) For locating the **grounding screw.**



Pump model, version and serial number must always be specified when ordering spare parts.

5. TECHNICAL FEATURES

MODEL	RPM	FLOW RATE		PRESSURE		POWER	
		l/min	GPM	PSI	Bar	Hp	kW
MF 45	800	267	70.6	2900	200	139	102.2
	1500	267	70.6			139	102.2
	1800	269	71			140	102.9
	2200	270	71.3			140	102.9
	2600	270	71.3			140	102.9
MF 50	800	330	87.2	2465	170	146	107.3
	1500	330	87.2			146	107.3
	1800	332	87.6			147	108.1
	2200	333	88			147	108.1
	2600	333	88			147	108.1
MF 55	800	399	105.4	2032	140	145	106.6
	1500	399	105.4			145	106.6
	1800	401	106			146	107.3
	2200	403	106.5			147	108.1
	2600	403	106.5			147	108.1

6. DIMENSIONS AND WEIGHT

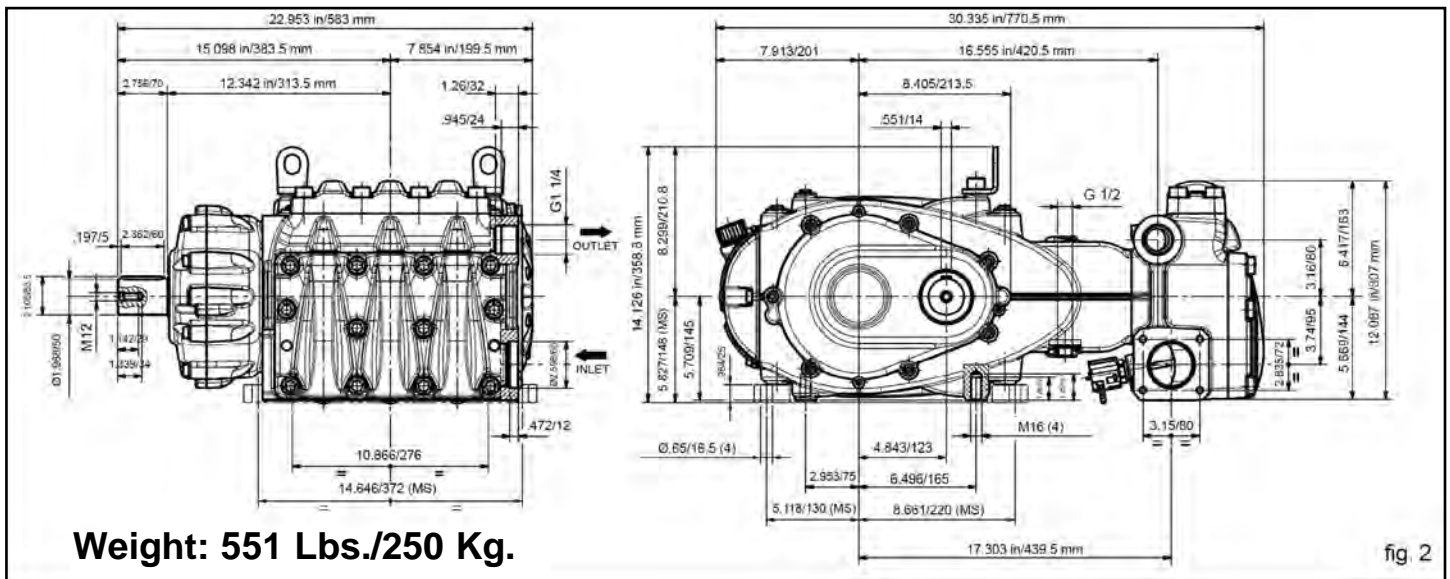

7. INFORMATION ABOUT PUMP USE



The MF pump, when not ordered with the ATEX configuration, is designed to operate in environments with atmospheres that are not potentially explosive, and with filtered water (see par. 9.7)

Other fluids may be used only upon the approval of The Customer Service Department.



7.1 Water Temperature

The max water temperature is 104⁰ F (40⁰ C). However, it is possible to use the pump at temperatures of up to 140⁰F (60⁰C) for short periods of time. In this case we advise consulting the Customer Service Department.

7.2 Max Pressure and Flow Rate

The performance values indicated in the catalog refer to the maximum performance of the pump. Regardless of the power used, pressure and maximum RPM values indicated on the plate may not be exceeded unless expressly authorized by the **Customer Service Department.**

7.3 Minimum Operating Speed

The minimum speed of the crankshaft for these types of pumps is 300 RPM. Any RPM value different from what is indicated in the performance table (see chapter 5) must be expressly authorized by the **Customer Service Department.**

7.4 Recommended Lubricant Oil Types & Manufacturers

The pump is delivered with lubricant oil compliant with room temperatures ranging between 32⁰ and 89.6⁰ F (0⁰ and 30⁰C). Some recommended lubricant types are indicated in the table below; these lubricants are treated with additives in order to increase corrosion protection and resistance to fatigue. As an alternative, Automotive SAE 85W-90 gearing lubricants may also be used.

BRAND	TYPE
GENERAL PUMP	SERIES 220
ARAL	Aral Degol BG 220
BP	ENERGOL HLP 220
CASTROL	Hyspin VG 220, Magna 220
ELF	POLYTELIS 220
ESSO	NUTO 220
FINA	Cirkan 220
FUCHS	RENOLIN 220
MOBIL	DTE OIL BB
SHELL	TELLUS C 220
TEXACO	RANDO HD 220
TOTAL	CORTIS 220



Set up the pump so that the oil temperature does not exceed in any case **212°F (100°C)** during pump operation.

Use a temperature probe to be inserted into the oil drain plug (2, fig. 3). See the "ATEX EXPLOSION PROTECTION" manual.

ATTENTION: Use only oil with flash point higher than 392°F (200°C).

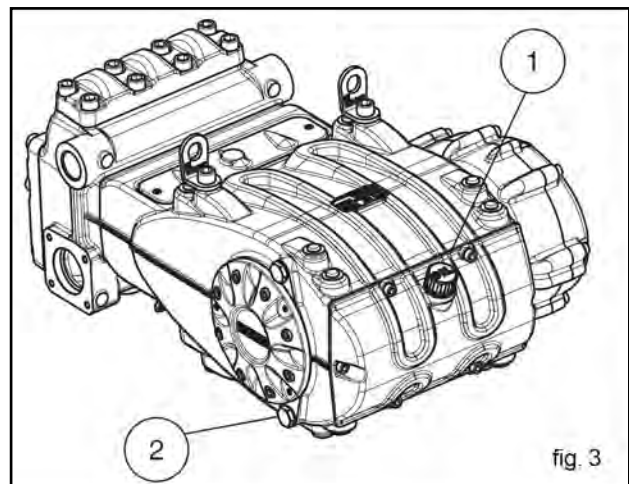

fig. 3

Check the oil level by using the oil level dipstick (1, fig. 3). Refill if necessary to top off level. Correct oil level inspection is done with the pump at room temperature; oil is changed with the pump at working temperature, by removing the rear plug (2, fig. 3).

Checking and changing oil is to be carried out as indicated in Chapter 11. The amount required is 287 oz. (8.5 liters) for pumps with reduction units and 253 oz (7.5 liters) for pumps with no reduction units.



In any case, oil must be changed at least once a year since it may deteriorate by oxidation.

For room temperatures that differ from that mentioned earlier, follow the indications contained in the diagram below, keeping in mind that the oil must have a minimum viscosity of 180 cSt.

VISCOSITY/ROOM TEMPERATURE DIAGRAM

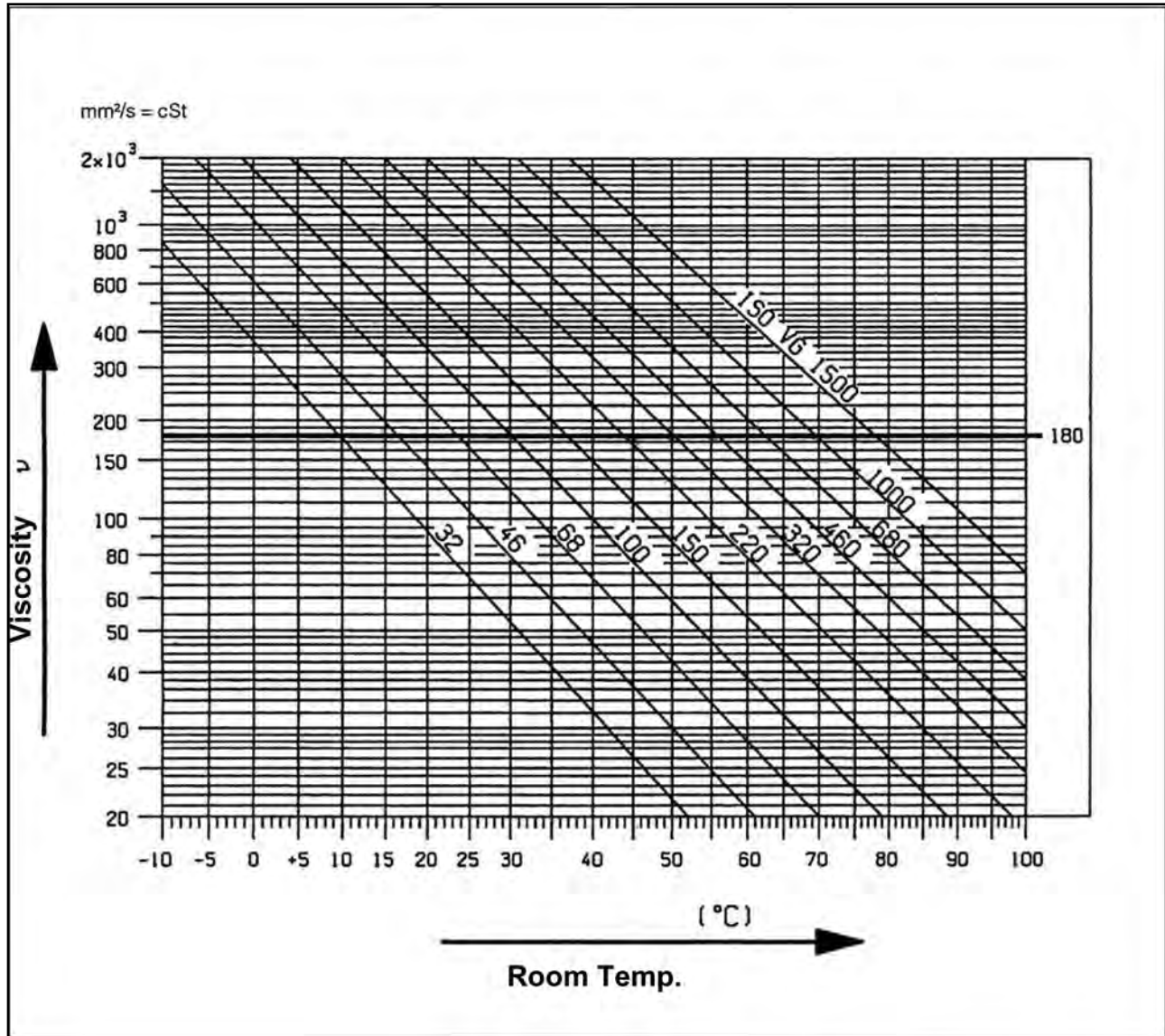

Exhausted oil must be collected in an appropriate container and disposed of in appropriate locations. In absolutely no case may it be dispersed into the environment.

8. PORTS AND CONNECTIONS

MF Series pumps are equipped with (see fig. 4):

1. 2 inlet ports "IN", Ø2.598 inch (66 mm) (on MF45, MF50, MF55 versions).

The line can be connected to either of the two inlet ports; the ones not being used must be hermetically sealed.

2. 2 outlet ports "OUT", G1 1/4" (on MF45, MF50, MF55 versions).
3. 1 drain port "DRAIN" with G1/2" hole in the lower cover to monitor any water leakage due to wear of the pressure packings. In case of leaks, please consult the repair manual.
This hole must always be kept open.

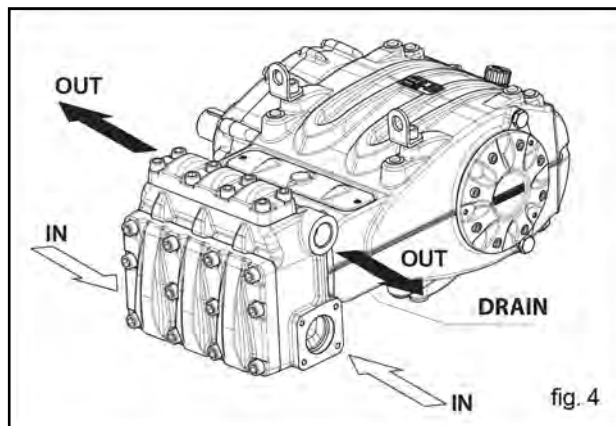

9. PUMP INSTALLATION

9.1 Installation

The pump must be installed in a horizontal position using the M16 threaded support feet. Tighten the screws with a torque of 200 Nm (147.5 Ft-Lb)

The base must be perfectly flat and rigid enough as not to allow bending or misalignment on the pump coupling and axis/transmission due to torque transmitted during operation.

Two lifting brackets are mounted on the pump for easy installation, as per the figure below.





The brackets are sized solely for pump lifting and therefore are absolutely not permitted for use of additional loads.



Replace the oil filling hole closing service plug positioned on the rear casing cover with the plug with oil dipstick. Check the correct quantity.

The dipstick must always be reachable, even when the unit is assembled.



Grounding: It is necessary to fix a grounding cable to the pump by means of the M8 stainless steel screw and the stainless steel toothed washer properly marked by the YELLOW label. See the "ATEX EXPLOSION PROTECTION" manual.



The pump's shaft (PTO) must not be rigidly connected to the motor unit.

The following transmission types are suggested:

- Flexible joint
- Cardan Joint (please respect the maximum working angles indicated by the manufacturer)
- Belts; for correct application, please contact the Customer Service Department.



In all cases, the transmission must be properly assembled to avoid incorrect or harsh operation of the connection parts and prevent excessive wear, an increase in temperature and/or hazardous breakages that may create potential sources of ignition and explosion. See the "ATEX EXPLOSION PROTECTION" manual.

9.2 Direction of rotation

The PTO rotation is indicated by an arrow located on the reduction gear cover. From a position facing the pump head, the rotation direction will be as in fig. 5.

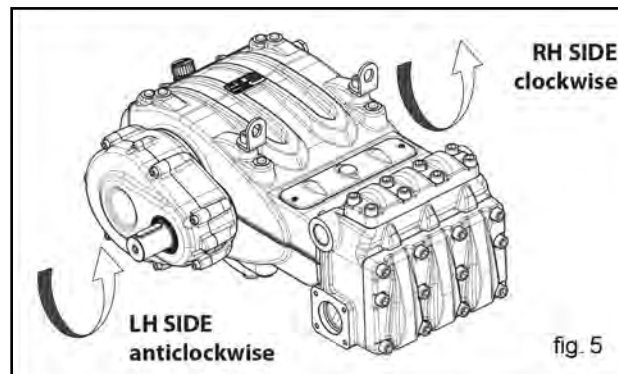

9.3 Version Change and Reducer Positioning

A right version pump is defined when: observing the pump from the head side, the PTO shank of the pump shaft is on the right side.

A left version pump is defined when: observing the pump from the head side, the PTO shank is on the left side. See fig. 5.



The version may be changed only by trained and authorized personnel by carefully following the instructions in the repair manual.

1. Separate the hydraulic part from the mechanical part as indicated in Chapter 2 in points 2.2.1 and 2.2.2 of the Repair Manual.
2. Turn the mechanical part 180° and reposition the rear casing cover in such a way that the oil dipstick is turned upward. Reposition the lifting bracket and relative hole closing plugs in the upper part of the casing. Invert the two inspection covers, ensuring that the open one is positioned lower. Finally, properly reposition the specification label in its housing on the casing.



Make sure that the lower inspection cover draining holes are open.

3. Reassemble the hydraulic part to the mechanical part as indicated in Chapter 2 in points 2.2.1, 2.2.4 and 2.2.5 of the Repair Manual.

It is also possible to place the reduction gear in 5 different positions as per fig. 6.

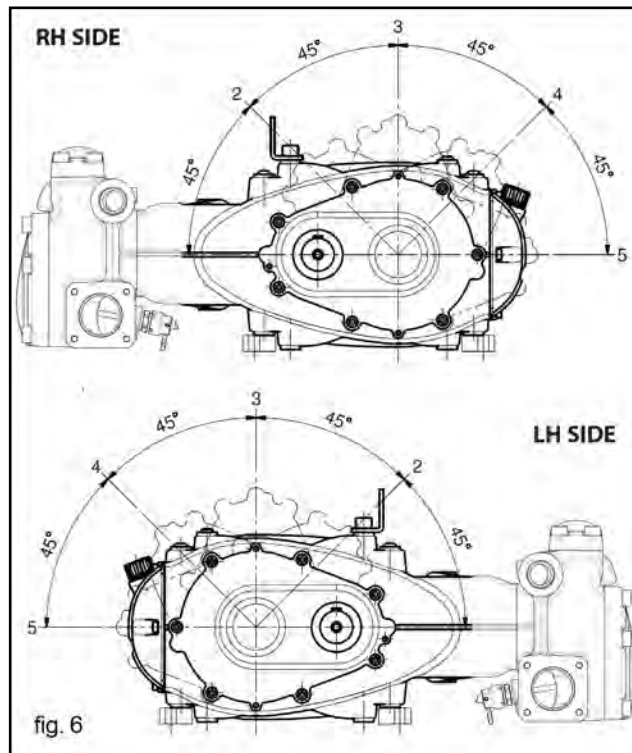

The reducer's position may be changed only by trained and authorized personnel by carefully following the instructions in the repair manual.

9.4 Hydraulic Connections

In order to isolate the system from the vibrations produced by the pump, we advise to build the first section of the duct near the pump (both for intake and delivery) with flexible hose. The consistency of the intake section must allow to avoid deformation caused by the depressurization produced by the pump.

9.5 Pump Power Supply

MF pumps must always be installed with a positive suction head i.e. they must receive water by gravity or by forced feeding, and never suctioned from a lower level. The pumps can tolerate minimum NPSH even as low as 1 m. (3.28 ft.), however, to obtain a better volumetric efficiency and above all to avoid cavitation, the minimum NPSH available, measured at the pump inlet flange, will have to be at least equal or higher than the values shown in the chart below.

	MF45	MF50	MF55
NPSH _r (ft)	7.5	8	9

Forced feeding by a booster pump is highly recommended in order to avoid cavitation, considering the geometry of the hydraulics and the considerable flow rates.

The booster pump must have the following specifications: flow rate at least double the rated flow rate of the pump, and pressure between 30 to 40 PSI (2 to 3 Bar). These feeding conditions must be respected at any operating RPM.



The booster pump must always be started up before the plunger pump. In order to protect the pump, we advise to install a pressure switch on the feeding line after the filters.

9.6 Suction Line

For the pump's correct operation, the suction line must have the following characteristics:

1. Minimum internal diameter as indicated in the diagram in paragraph 9.9, and in any case equal or greater than the pump head's value.



Along the duct, avoid localized diameter reductions that may cause pressure drops with subsequent cavitation. Absolutely avoid 90° elbows, connections with other hoses, bottlenecks, counter-slopes, upside down "U" shaped curves, "T" connections.

2. With a layout that is set in such a way to prevent cavitation.
3. It should be perfectly airtight, and built in a way that guarantees perfect sealing over time.
4. Avoid pump emptying when stopping (even partial emptying).
5. Do not use hydraulic fittings, 3 or 4 way fittings, adapters, swivel joints, etc., since they may hinder the pump's performance.
6. Do not install Venturi tubes or injectors for detergent intake.
7. Avoid the use of base valves or any other type of one-way valves.
8. Do not connect the by-pass line from the valve directly to the pump suction line.
9. Provide appropriate baffle plates inside the tank in order to avoid water flows coming from both the by-pass and feeding lines which may create turbulence near the tank's outlet port.
10. Make sure that the suction line is perfectly clean inside before connecting it to the pump.
11. The pressure gauge for checking booster pressure must be installed near the plunger pump's inlet port, and always downstream from the filters.

9.7 Filtering

On the suction line, install two filters as indicated in fig. 7 and fig. 7/a.

With the manual adjustment valve:

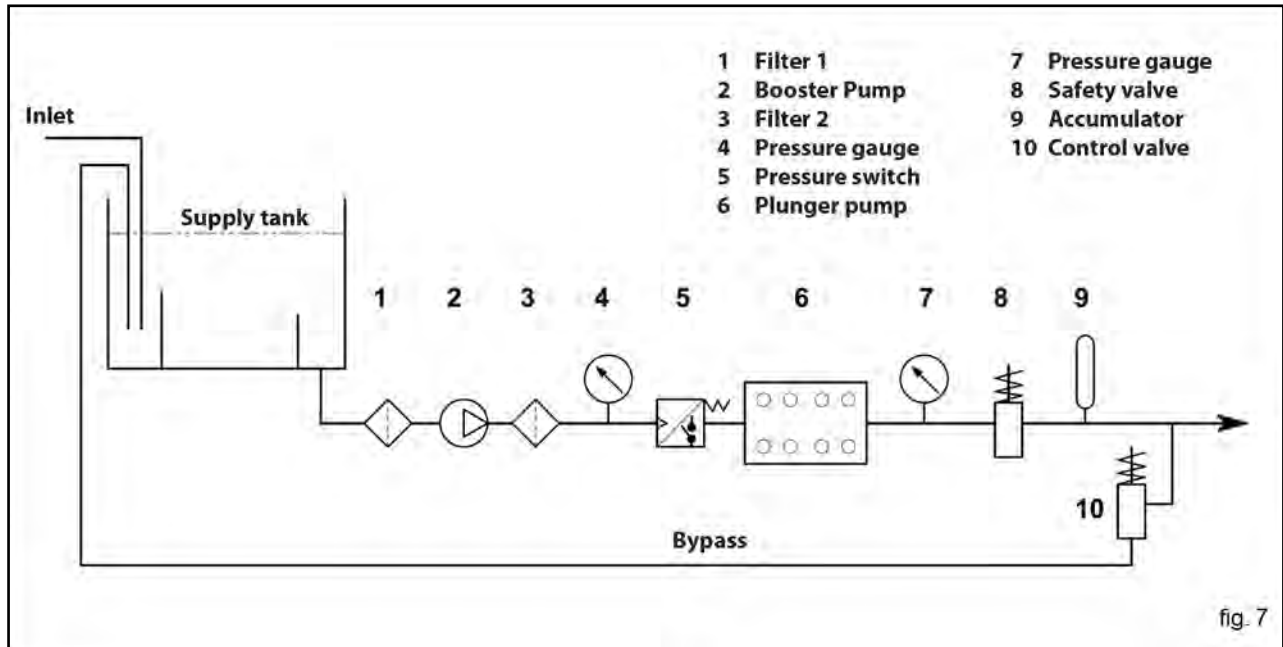

With the pneumatic adjustment valve:

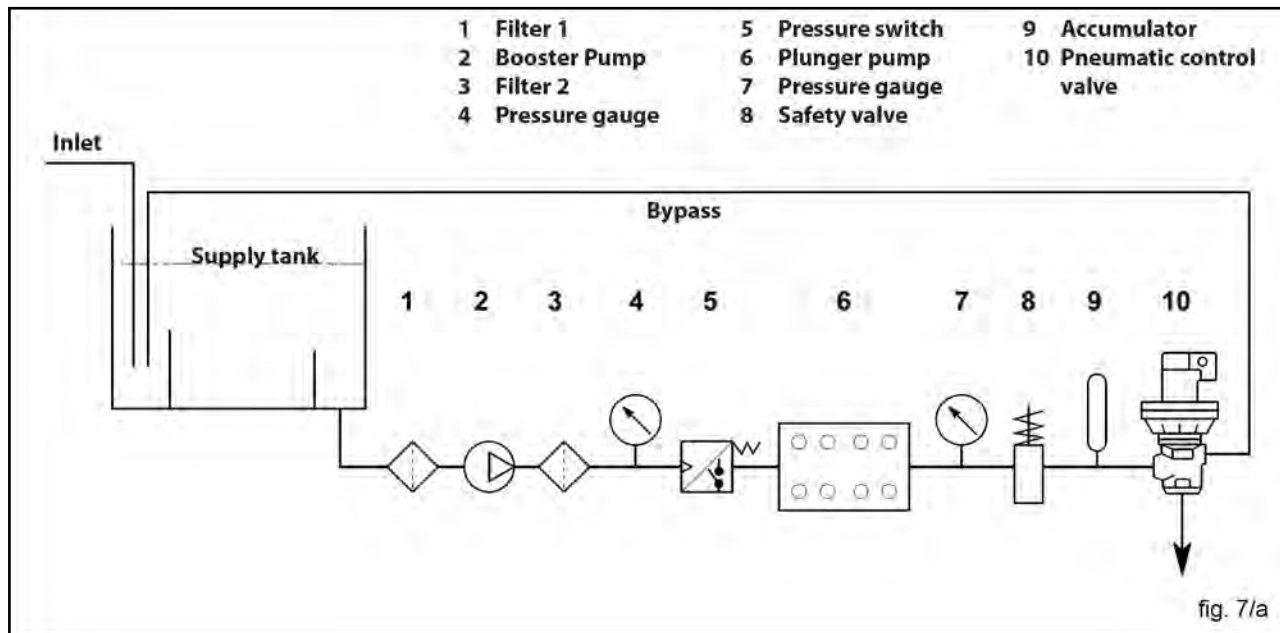

The filter must be installed as close as possible to the pump, should allow easy inspection and have the following characteristics:

1. Minimum capacity 3 times greater than the pump's rated flow value.
2. Filter port diameters must not be smaller than the pump inlet ports.
3. Filtration degree ranging between 200 and 360 μm .



In order to guarantee correct pump operation, it is important to plan periodical cleaning of the filter depending on actual pump usage, water quality and actual clogging conditions.

9.8 Outlet Line

To obtain a correct delivery line, please comply with the following installation instructions:

1. The internal diameter of the hose must allow to guarantee correct fluid speed; see diagram in paragraph 9.9
2. The first section of the hose connected to the pump must be flexible in order to isolate pump vibrations from the rest of the system.
3. Use high pressure hoses and fittings that guarantee wide safety margins in any working condition.
4. Install a safety valve on the delivery line.
5. Use pressure switches suitable for the pulsating loads typical of plunger pumps.
6. In the design phase, take into proper account the pressure drop along the line, since this causes a reduction in usage pressure with respect to the value measured at the pump.
7. If the pump pulsations are harmful for particular applications, install an appropriately sized pulsation dampener on the outlet line.

9.9 Internal Diameter of the Hose Line

To determine the internal diameter of the hose, please refer to the following diagram.

Suction Hose

With a flow rate of ~105 GPM (400 l/mn) and water speed of 1 m/sec. the diagram line that connects the two scales intersects the central scale, indicating the diameters, at a value of ~ 3.5 inch (90 mm).

Delivery Hose

With a flow rate of ~105 GPM (400 l/mn) and water speed of 5.5 m/sec. The diagram line that connects the two scales intersects the central scale, indicating the diameters at a value of ~ 1.6 inch (40 mm).

Optimal speed to be obtained with the booster pump:

- Suction: ≤ 1 m/sec.
- Delivery: ≤ 5.5

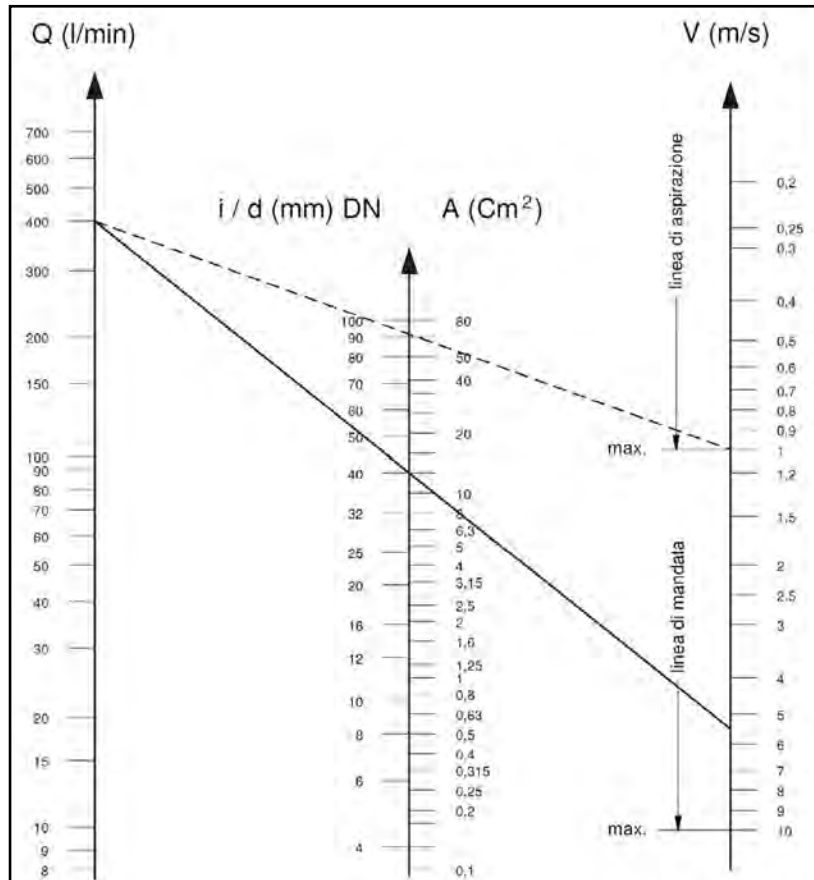

The diagram does not take into account the hose and valve resistance, the pressure drop due to the pipe length, the viscosity and the temperature of the pumped fluid. If necessary, contact our Customer Service Department.

9.10 V-belt Transmission

As indicated in paragraph 9.1, only in exceptional cases may the pump be driven by a v-belt system. For correct lay-out sizing, please contact our Customer Service Department.

9.11 Transmission of power from the second PTO

Upon request the MF series pump can be supplied with an auxiliary PTO on the opposite side to drive. Transmission can be carried out:

- By means of V-belts
- By means of a coupling

With V-Belts, Max Torque output is: 110 ft/lb (150 Nm) corresponding to 17 HP (12.5 kW) at 800 rpm.

With coupling, Max Torque output is: 162 ft/lb (220 Nm) corresponding to 25 HP (18.4 kW) at 800 rpm.



With transmission by means of coupling, pay close attention to perfectly align, so that no transverse forces are generated on the pump shaft. If necessary, contact our Customer Service Department.

10. START-UP AND OPERATION

10.1 Preliminary Inspections

Before Start-up Be sure that:



The suction line is connected and up to pressure (see Chapter 9) the pump must never run dry.

1. The suction line must be perfectly airtight.
2. All the On-Off valves between the pump and the feeding source are completely open. The delivery line must discharge freely in order to allow the air in the pump to be expelled easily, thus facilitating pump priming.
3. All suction/delivery connections and fittings must be correctly tightened.
4. Coupling tolerances on the pump/transmission axis (half-joint misalignment, Cardan joint tilt belt tightening, etc.) must remain within the limits indicated by the transmission Manufacturer.
5. The pump's oil level must be verified using the correct dipsticks (position 1, fig 8).

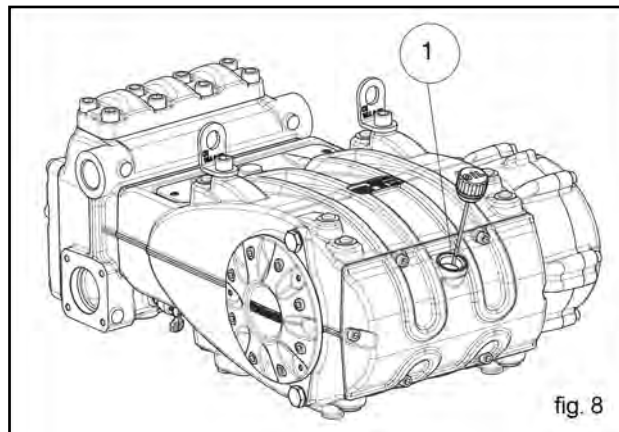



In case the pump has not run for a long period of time, recover the correct operation of the suction valves by opening the three valve-lifting devices (see position 2, fig. 9). Be sure to reclose the valves before the pump start-up. See fig. 10 for “work” and “rest” positions.

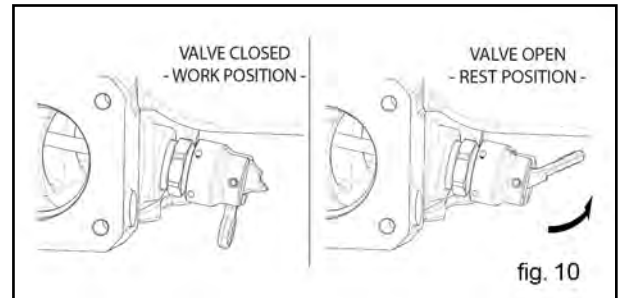
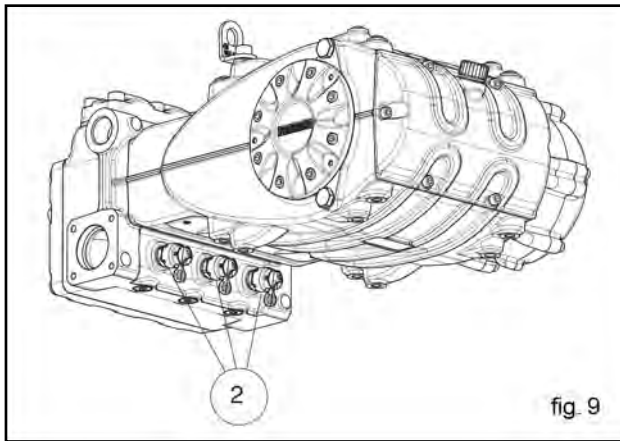

10.2 Start-up

1. When starting the pump for the first time, check for the correct direction of rotation.
2. Verify correct feeding pressure.
3. The pump must be started off-load.
4. During operation, check that the rotating speed does not exceed the rated value.
5. Before putting the pump under pressure let it run for at least 3 minutes.
6. Before stopping the pump, release the pressure by acting on the adjustment valve or on any discharging device.

11. PREVENTIVE MAINTENANCE

To guarantee pump reliability and efficiency, comply with the maintenance intervals as indicated in the table below.

PREVENTIVE MAINTENANCE	
EVERY 500 HOURS	EVERY 1500 HOURS
Check oil level	Change oil
	Check / Replace:* Valves Valve seats Valve springs Valve guides
	Check / Replace: H.P packings L.P. packings

* For replacement follow instructions contained in the repair manual.



Attention: On pumps without reduction unit, replace bearings and the corresponding seal rings every 7000 hours of operation. On pumps with a reduction unit, replace all the bearings and the corresponding seal rings every 10000 hours of operation. Perform periodical checks on cleaning and maintenance on the pump. See the “ATEX EXPLOSION PROTECTION” manual.

12. PUMP STORAGE

12.1 Filling the Pump With An Anti-Corrosion Emulsion or Anit-freeze By Using An External Diaphragm Pump As In The Layout Shown in Paragraph 9.7.

- a) Close the filter draining, if open.
- b) Be sure that the connecting hose is clean, spread with grease and connect it to the high pressure outlet port.
- c) Fit a suction hose to the diaphragm pump. Open the pump suction connection and fit hose between it and the diaphragm pump.
- d) Fill the container with the solution/emulsion.
- e) Put the free extremities of the suction line and the high pressure outlet hose inside the container.
- f) Start up the diaphragm pump.
- g) Pump the emulsion until it comes out of the high pressure hose.
- h) Continue pumping for at least another minute; if needed, the emulsion can be reinforced by adding, for example, Shell Donax
- i) Stop the pump, remove the hose from the suction connection and close it with a plug.
- j) Remove the hose from the high pressure outlet port. Clean, grease and plug both connections and the hoses.

12.2 Hoses

- a) Before greasing and protecting the hoses according to the previously described procedure, dry the connections using compressed air.
- b) Cover with polyethelene.
- c) Do not wrap them too tightly; be sure there is no bending.

13. PRECAUTIONS AGAINST FREEZING



In areas and periods of the year where there is risk of freezing, follow the instructions indicated in Chapter 12 (see paragraph 12.2).



In the presence of ice, do not start the pump for any reason until the circuit has been fully defrosted, otherwise there can be serious damage to the pump.

14. WARRANTY TERMS

The pump is guaranteed for a period of 5 years from the delivery date, with the exception of parts subject to wear. In any case, please refer to the contract terms for other warranty conditions. The warranty is void if:

- a) The pump has been used for purposes that differ from that agreed.
- b) The pump has been fit with an electric or diesel engine with performance greater than that indicated in the table.
- c) The required safety devices were un-adjusted or disconnected.
- d) The pump was used with accessories or spare parts not supplied by General Pump.
- e) Damage was caused by:
 - 1) improper use
 - 2) the non-observance of maintenance instructions
 - 3) use not compliant with operating instructions
 - 4) insufficient flow rate
 - 5) faulty installation
 - 6) incorrect positioning or sizing of the hoses
 - 7) non-authorized design changes
 - 8) cavitation

15. TROUBLESHOOTING**The pump does not produce any noise at start-up:**

- The pump is not primed and is running dry
- There is no water in the inlet line
- The valves are blocked
- The delivery line is closed and does not allow the air in the pump to be discharged

**The pump pulses irregularly (knocking):**

- Air suction
- Insufficient feeding
- Bends, elbows, fittings along the suction line obstruct the fluid's passage
- The inlet filter is dirty or too small
- The booster pump, where provided, supplies insufficient pressure or flow rate
- The pump is not primed due to insufficient head or the delivery line is closed during priming
- The pump is not primed due to valve seizing
- Worn valves
- Worn pressure packings
- Incorrect operation of the pressure adjustment valve
- Transmission problems

**The pump does not deliver the rated flow / is noisy:**

- Insufficient feeding (see the causes listed above)
- RPM are less than the rated flow
- Excessive amount of water by-passed by the pressure adjustment valve



- Worn valves
- Leakage from the pressure packings
- Cavitation due to:
 - 1) Wrong sizing of the suction hose/undersized diameters
 - 2) Insufficient flow rate
 - 3) High water temperature

**Insufficient pump pressure:**

- The nozzle (or has become) too large
- Insufficient RPM
- Leakage from the pressure packings
- Incorrect operation of the pressure adjustment valve
- Worn valves

**Overheated pump:**

- The pump is overloaded (pressure or RPM exceed the rated values)
- Oil level is too low, or the oil is not of a suitable type, indicated in Chapter 7 (see paragraph 7.4)
- Incorrect alignment of the joint or pulleys
- Excessive inclination of the pump during operation

**Pump vibrations or knocking:**

- Air suction
- Incorrect operation of the pressure adjustment valve
- Valve malfunction
- Irregular drive transmission motion

16. EXPLODED VIEW AND PARTS LIST

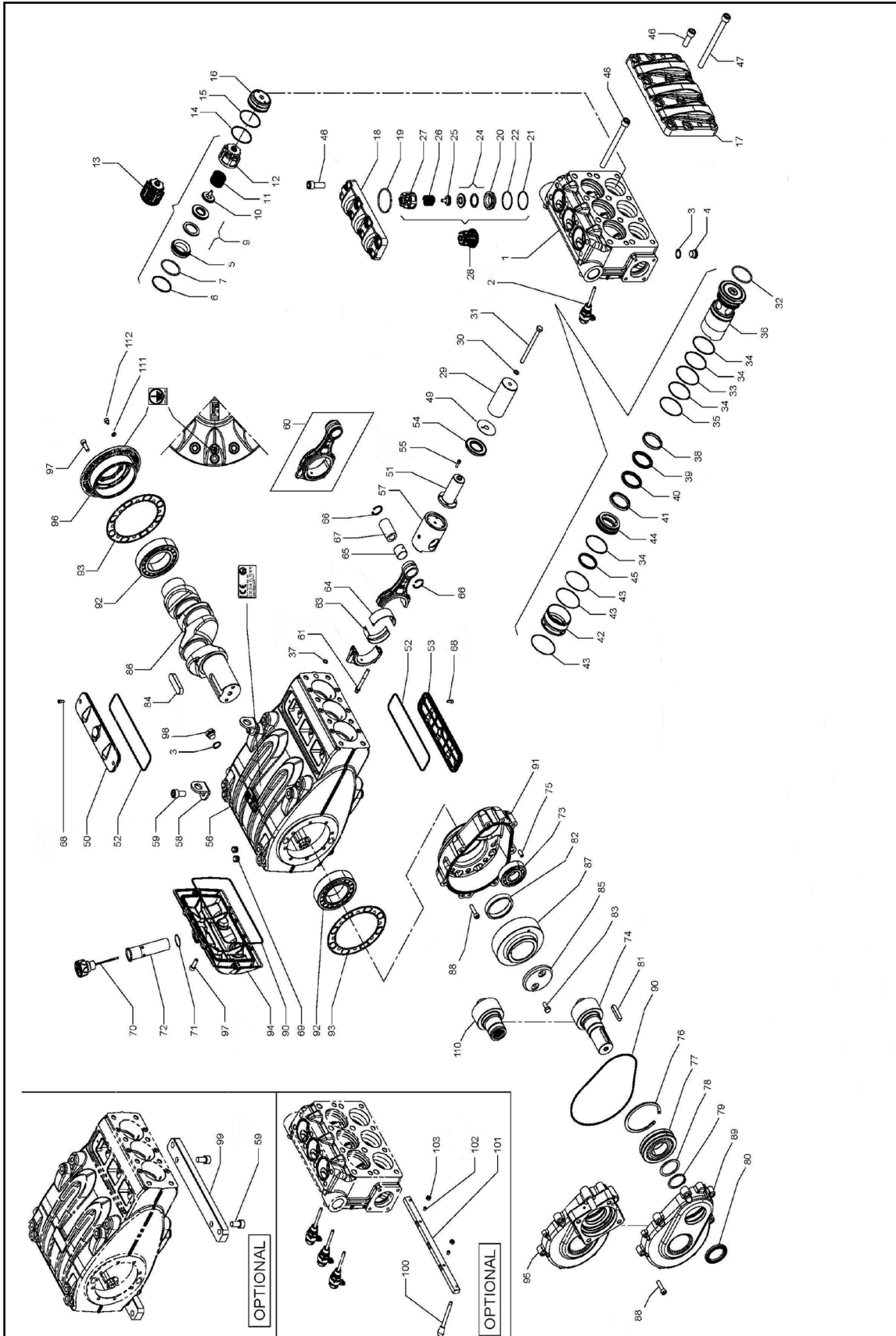

Item	Part #	Description	QTY.
1	F73121115	MANIFOLD (45-50)	1
	F73121215	MANIFOLD (55)	
2	F10755401	VALVE OPENING DEVICE	3
3	96751400	WASHER Ø 21.5X27X1.5	5
4	F98218500	STEEL PLUG	3
5	F36206666	INLET VALVE HOUSING	3
6	F90527000	ANTI-EXTRUSION RING, Ø 61.2X67X2	3
7	F90410500	OR Ø59.62X3.53	3
9	F36208701	BALL VALVE ASSY.	3
10	F36208951	INTERNAL VALVE GUIDE	3
11	F94769800	SPRING, Ø 41.5X37.9	3
12	F36206005	INLET VALVE GUIDE	3
13	F36715001	INLET VALVE UNIT	3
14	F90391100	OR Ø 66.35X2.62	3
15	F90528200	ANTI-EXTRUSION RING, Ø 68.0X72.0X1.5	3
16	F73221556	INLET VALVE PLUG	3
17	F73221415	INLET VALVE COVER	1
18	F73210915	OUTLET VALVE COVER	1
19	F90412000	OR, Ø 68.28X3.53	3
20	F36206766	OUTLET VALVE HOUSING	3
21	F90526000	ANTI-EXTRUSION RING Ø 51.5X56.0X1.5	3
22	F90389000	OR Ø 50.47X2.62	3
24	F36208801	BALL VALVE ASSY.	3
25	F36206766	INTERNAL VALVE GUIDE	3
26	F94760500	SPRING Ø28.5X32	3
27	F36206105	OUTLET VALVE GUIDE	3
28	F36207701	OUTLET VALVE UNIT	3
29	F73040309	PLUNGER Ø 45X117	3
	F73040409	PLUNGER Ø 50X117	
	F73040509	PLUNGER Ø 55X117	
30	F96710500	WASHER , Ø 10.0X18.0X0.9	3
31	F99383000	SCREW M10X140	3
32	F90411500	OR Ø 63.5X3.53	3
33	F90528550	ANTI-EXTRUSION RING, Ø 72.9X77.0X1.5 (MF45-50)	3
	F90527000	ANTI-EXTRUSION RING, Ø 79.8X80.0X1.5 (MF55)	
34	F90391400	OR, Ø 72.69X2.62 (MF55)	12
	F90391350	OR, Ø 71.12X2.62 (MF45-50)	
35	F90528650	ANTI-EXTRUSION RING, Ø 74.9X79.0X1.5 (MF55)	3
	F90528400	ANTI-EXTRUSION RING, Ø 71.9X76.8X1.5	
36	F73221856	CYLINDER SEAL Ø 45	3
	F73221956	CYLINDER SEAL Ø 50	
	F73222056	CYLINDER SEAL Ø 55	
37	701111	OR, Ø 10.78X2.62	6
38	F74100192	PISTON HEAD RING, Ø 45	3
	F74100292	PISTON HEAD RING, Ø 50	
	F74100392	PISTON HEAD RING, Ø 55	
39	90285000	SEAL RING, Ø 45.0X60.0X4.5/7.5 HP	3
	F90286300	SEAL RING, Ø 50.0X65.0X7.5/4.5 HP	
	F90287300	SEAL RING, Ø 55.0X70.0X5.0/4.5 HP	
40	F90284800	RESTOP RING, Ø 45	3
	F90286500	RESTOP RING, Ø 50	
	F90287500	RESTOP RING, Ø 55	
41	F73222170	CENTERING RING Ø 45	3
	F73222270	CENTERING RING Ø 50	
	F73222370	CENTERING RING Ø 55	
42	F73221691	CENTERING HEAD BUSHING Ø 45-50	3
	F73221791	CENTERING HEAD BUSHING Ø 55	
43	F90371000	OR, Ø 81.0X2.0	9
44	F73080056	BOTTOM RING Ø 45	3
	F73080156	BOTTOM RING Ø 50	
	F73080256	BOTTOM RING Ø 55	
45	F90284600	SEAL RING, Ø 45.0X53.0X5.5 LP	3
	F90286000	SEAL RING, Ø 50.0X58.0X5.5 LP	
	F90287000	SEAL RING, Ø 55.0X63.0X5.5 LP	
46	F99514200	SCREW M16X45	14
47	F99522500	SCREW M16X200	6
48	F99522200	SCREW M16X180	2
49	F96735500	WASHER Ø 16.0X65.0X1.0	3

Item	Part #	Description	QTY.
50	F73150022	CLOSED INSPECTION COVER	1
51	F73050636	PLUNGER GUIDE ROD	3
52	F90414800	OR Ø 202.8X3.53	2
53	F73150122	OPEN INSPECTION COVER	1
54	F90168500	RAD. RING Ø 40.0X72.0X7.0/8.5	3
55	F99188400	SCREW M6X20	12
56	F73010213	PUMP CASING	1
57	F79050443	PLUNGER GUIDE	3
58	F73210674	LIFTING BRACKET	2
59	F99513000	SCREW M16X30	4
60	F73030301	CONNECTING ROD ASSY.	3
61	F99378800	CONNECTING ROD SCREW	6
63	F90928300	CONROD HEAD SEMI-BUSHING LOWER - INF	3
	F90928100	CONROD HEAD SEMI-BUSHING LOWER +0.25	
	F90928200	CONROD HEAD SEMI-BUSHING LOWER +0.50	
64	F90928000	CONROD HEAD SEMI-BUSHING UPPER - INF	3
	F90928400	CONROD HEAD SEMI-BUSHING UPPER +0.25	
	F90958500	CONROD HEAD SEMI-BUSHING UPPER +0.50	
65	F90917300	CONROD BUSHING	3
66	F90069700	STOP RING Ø 35	6
67	F97745000	SPINDLE	3
68	99183700	SCREW M6X14	4
69	98206000	HOLE PLUG Ø 15	6
70	F98233500	OIL FILLING PLUG G1"	1
	F98233600	OIL FILLING PLUG G1" - ATEX	
71	90361600	OR Ø 34.65X1.78	1
72	F73210295	TUBE FOR OIL FILLING PLUG, G1"	1
73	F91854000	CY. ROLLER BEARING	1
74	F10076735	PINION, Z24 Ø 1.875, HELICOL	1
	F10076835	PINION, Z21 Ø 2.238, HELICOL	
	F10076935	PINION, Z18 Ø 2.722, HELICOL	
	F10082255	PINION, Z19 Ø 3.211, HELICOL	
75	F97623000	TMP. CYL. PIN. Ø 10.0X24.0	2
76	F90101000	STOP RING Ø 120	1
77	F91859900	ADJUST. ROLLER BEARING	1
78	F73210455	BEARING SUPPORT RING	1
79	F90081000	STOP RING Ø 55	1
80	F90172400	RAD. RING, Ø 55.0X75.0X8.0, VITON	1
81	F91500500	TAB, 14.0X9.0X60.0	1
82	F73210589	RING GEAR SUPPORT RING	1
83	9936700	SCREW M10X25	2
84	F91511000	TAB, 22.0X14.0X80.0	1
85	F74213255	RING GEAR STOP	1
86	F73020035	CRANKSHAFT C.70	1
87	F10077035	RING GEAR, Z46 R.1.875 HELICAL	1
	F10077135	RING GEAR, Z47 R.2.238 HELICAL	
	F10077235	RING GEAR, Z49 R.2.722 HELICAL	
	F10082355	RING GEAR, Z61 R.3.211 HELICAL	
88	F99371000	SCREW M10X40	15
89	F73210113	REDUCTION GEAR COVER	1
90	F90415000	OR, Ø 253.6X3.53	2
91	F73210013	REDUCTION GEAR BOX	1
92	F91881000	CY. ROLLER BEARING	2
93	F73210384	SIDE SEAL	2
94	F73160022	CASING COVER	1
96	F73150222	BEARING COVER	1
97	F99368600	SCREW M10X30	14
98	F98218700	PLUG G1/2"X10	2
	F98218700	PLUG G1/2"X10 - ATEX	
	F98208150	PLUG G1/2"X13 - ATEX	
99	F73200064	FOOT	2
100	F94540000	LEVER M8X107	1
101	F73215864	VALVE LIFTER BRACKET	1
102	F99301800	SCREW M8X10	2
103	F92221800	SCREW M8X1.5X5X13	2

REPAIR KITS

KIT NUMBER	F2312 (MF45) Plunger Pack.	F2313 (MF50) Plunger Pack.	F2314 (MF55) Plunger Pack.	F2142 Inlet Valve	F2062 Outlet Valve	F2315 (MF45) Complete Seals	F2316 (MF50) Complete Seals	F2317 (MF55) Complete Seals	F2150 Conn. Rod	F2151 Conn. Rod	F2153 Conn. Rod	F2152 Mounting Feet	F2189 Valve lifter junction
Positions Included	32, 33, 34, 35, 37, 39, 40, 43, 45	32, 33, 34, 35, 37, 39, 40, 43, 45	32, 33, 34, 35, 37, 39, 40, 43, 45	13	28	6, 7, 14, 15, 19, 21, 22, 32, 33, 34, 35, 37, 39, 40, 43, 45, 52, 54, 71, 80, 90, 93	6, 7, 14, 15, 19, 21, 22, 32, 33, 34, 35, 37, 39, 40, 43, 45, 52, 54, 71, 80, 90, 93	6, 7, 14, 15, 19, 21, 22, 32, 33, 34, 35, 37, 39, 40, 43, 45, 52, 54, 71, 80, 90, 93	63, 64	63, 64	63, 64	59, 99	101, 102, 103

18. MAINTENANCE LOG

HOURS & DATE

OIL CHANGE							
GREASE							
PACKING REPLACEMENT							
PLUNGER REPLACEMENT							
VALVE REPLACEMENT							



GP Companies, Inc.
1174 Northland Drive
Mendota Heights, MN 55120
Phone: 651.686.2199 Fax: 800.535.1745
www.generalpump.com email: sales@gpcompanies.com

Ref 310069 Rev. C
02-20